

Feel Safe Feel Secure

Tested for Integrity & Stability



الحلول الميكانيكية والتقنية ش م م
MECHANICAL & TECHNICAL SOLUTIONS LLC



Table of Contents



● INTRODUCTION	2
● OUR PRODUCTS	3
● FEATURES & BENIFITS	4
● DOOR DESIGNS	5
● FRAME PROFILE	6
● DOOR CONSTRUCTION	8
● STAINLESS STEEL DOORS & FRAMES	9
● TECHNICAL SPECIFICATION	10
● STANDARD FINISH	12
● CERTIFICATES	14
● PLANT LOCATION MAP	



Introduction



THE COMPANY

MECHANICAL & TECHNICAL SOLUTIONS L.L.C. **M&T** commenced its Architectural Metal Works operations in 2008, and has since been able to provide the best and most professional solutions to any new challenges, by fabricating quality products and systems conforming to the highest standards of industry practice and carving a niche for itself in a highly competitive industry.

M&T Steel Door is the first of its kind in the Sultanate of Oman. The Factory is equipped with most modern computerized machines capable to manufacture and supply wide range of high quality custom made fire rated and non fire rated steel doors and frames.

The production will cater to the needs of various education, health, defense, hospitality and government institutions, and to all industrial, commercial and residential projects.

M&T Steel Doors assure you of safety and security, as the doors and frames are:

1. Conforming to American and British Standards.
2. Certified by UL, Certifire, Intertek, Public Authority for Civil Defence and Ambulance (Sultanate of Oman), Civil Defence (Dubai, UAE), Civil Defence (State of Qatar), Civil Defence (Kingdom of Bahrain), Civil Defence (Iran), Petroleum Development Oman (PDO) and Ministry of Defence Oman (MOD).
3. Manufactured with advanced technology using most modern computerized machines.
4. The Plant is managed by well experienced team of managers, engineers and technicians.
5. The Company is an ISO 9001:2008 certified, assuring to provide best quality product supported by quality management system.



Our Products



- FIRE RATED STEEL DOORS
- ACOUSTIC STEEL DOORS
- NON FIRE RATED STEEL DOORS
- SLIDING DOORS
- ACCESS PANELS
- STEEL WINDOWS
- STEEL SCREENS
- SECURITY DOORS
- STAINLESS STEEL DOORS
- GRILL DOORS



Features & Benefits

Steel Doors

Local authorities, housing associations, national major house builders and regional developers have all chosen to combine the visual appeal of traditional panelled doors with the energy saving, easy care characteristics that make original steel doors such high performers. They meet the exacting standards of newly built homes and provide an aesthetically acceptable means of improving the thermal performance of entry systems in older properties.

Features & Benefits

- ✓ Original Steel doors are available in a wide choice of traditional, cottage and contemporary styles.
- ✓ Available primed for on-site painting or pre-finished in a choice of standard colours.
- ✓ Steel composite doors provide an effective alternative to solid timber doors but do not warp, bow or split.
- ✓ Excellent sound and thermal performance.
- ✓ Thermal insulation value up to four times that of a solid timber door.
- ✓ Environmentally friendly polyurethane insulating foam core.
- ✓ Durable construction with galvanised steel skins.
- ✓ Available in a range of standard sizes particularly suitable for new build applications.
- ✓ Available with a wide range of ironmongery and glazing options.
- ✓ Long lasting and low maintenance.



Door Designs



FF - Full Flush



VS - Vision Square



VR - Vision Round



VNS - Vision Narrow Short

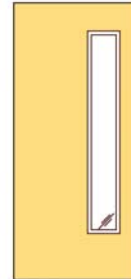

VNL - Vision Narrow Long

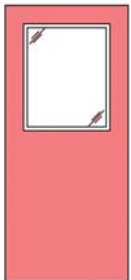

HG - Half Glaze



FG - Full Glaze



BL - Bottom Louver



TL - Top Louver



FL - Full Louver



VNS/BL - Vision Narrow short with Bottom Louver



HG/BL - Half Glaze with Bottom Louver



VS/BL - Vision square with Bottom Louver



VR/BL - Vision Round with Bottom Louver



TBL - Top and Bottom Louver

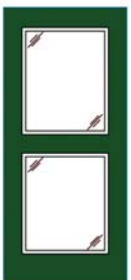

TBG - Top and Bottom Glaze



FF/TP - Full Flush with Top Panel

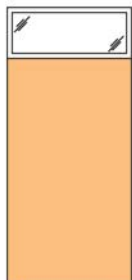

FF/TG - Full Flush with Top glaze



FF/TL - Full Flush with Top louver



VS, BL/TG - Vision Square, Bottom Louver with Top glaze

Frame Profile

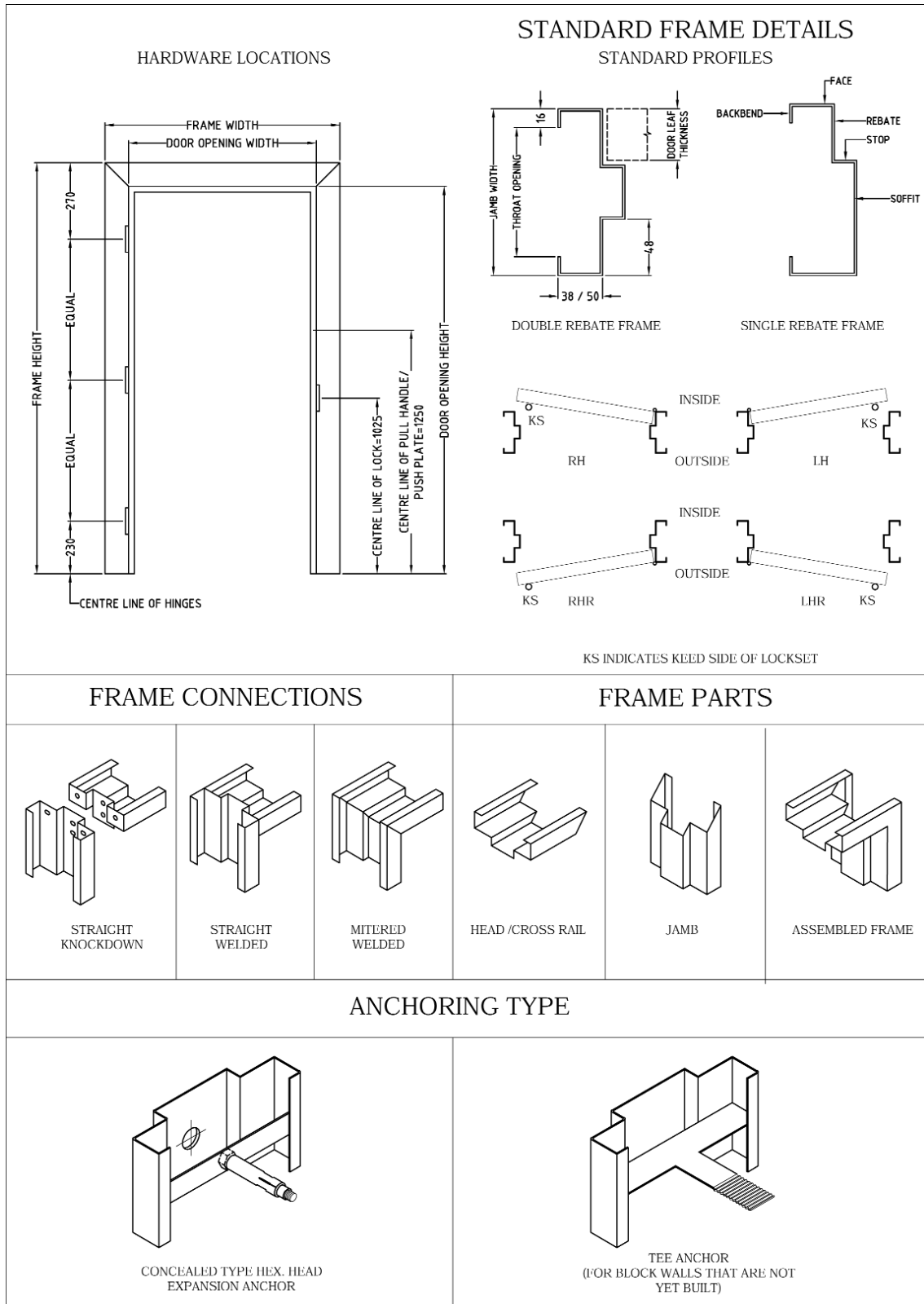

Frame Profile

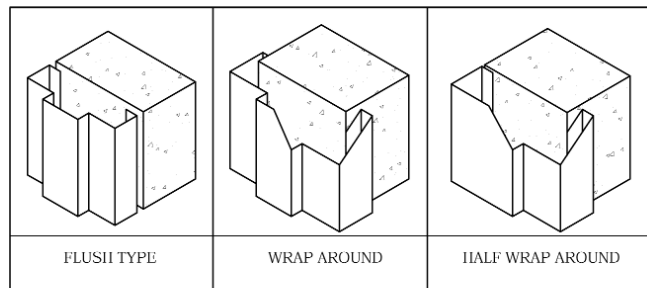
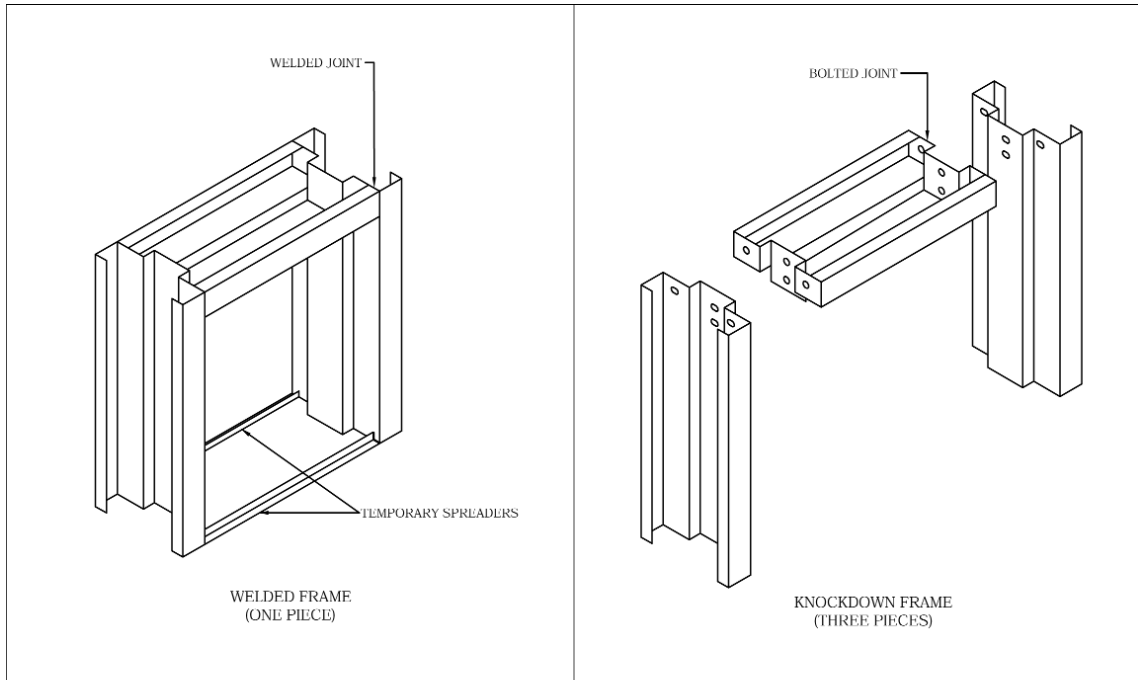

FRAME TYPES

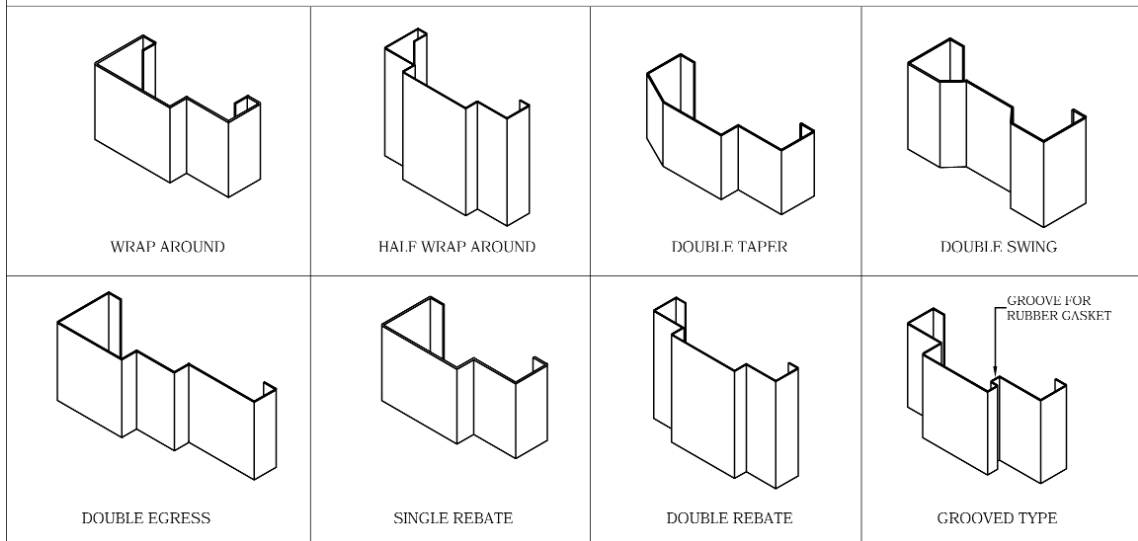

Door Construction

Honey Comb Core:

Honeycomb core is made from layers of paper or cardboard bonded together by parallel and uniformly spaced lines of adhesive light weight and high strength. Glued to the interior surface of the door skin, door leaf is pressed for a couple of hours to maintain the flatness of the door. Compressive strength is equal to 1.4kg/sq.cm.



Polystyrene core:

A rigid closed cell polystyrene in density range from 20 to 35 kg/cu.m. It has a stable thermal conductivity value that ensures insulation efficiency for long time. Commonly used for our non-fire rated doors.



Mineral Core:

Made from molten basalt rocks spun to fine fibers and bonded with thermosetting phenolic resin used for thermal insulation, acoustical and fire barrier. Provided with suitable vertical stiffeners.



Stainless Steel Doors & Frames

M&R[®] stainless steel doors and frames become a judicious choice when you need greater corrosion resistance or an aesthetical look.

TECHNICAL DETAILS

M&R[®] manufactures its doors from a #304 type stainless steel with a #4 finish for projects where stainless steel beauty and prestige are displayed prominently.

For projects that require durability, M&R[®] uses a #316 type stainless steel with a #4 finish which offers a higher resistance to corrosion.

Stainless steel products have a variety of applications where they present superior performance:

- Public pools
- Food processing factories
- Laboratories
- Chemical product warehouses
- Automatic car wash
- The frames are manufactured from 1.5mm stainless steel and can be set up and welded or knockdown;
- The doors are built from 1.2mm or 1.5mm stainless steel.
- The frames and doors are strengthened, mortised, drilled and threaded in order to receive the specified hardware;
- All the components required in this type of doors are manufactured from stainless steel.

For all of the architectural projects, no doubt the stainless steel is a contemporary and durable choice.

The M&R[®] stainless steel doors and frames are chosen for their characteristics :

- Aesthetics;
- Excellent resistance to the corrosion and to chemicals;
- Heat and fire resistance;
- Easy maintenance.



Technical Specification

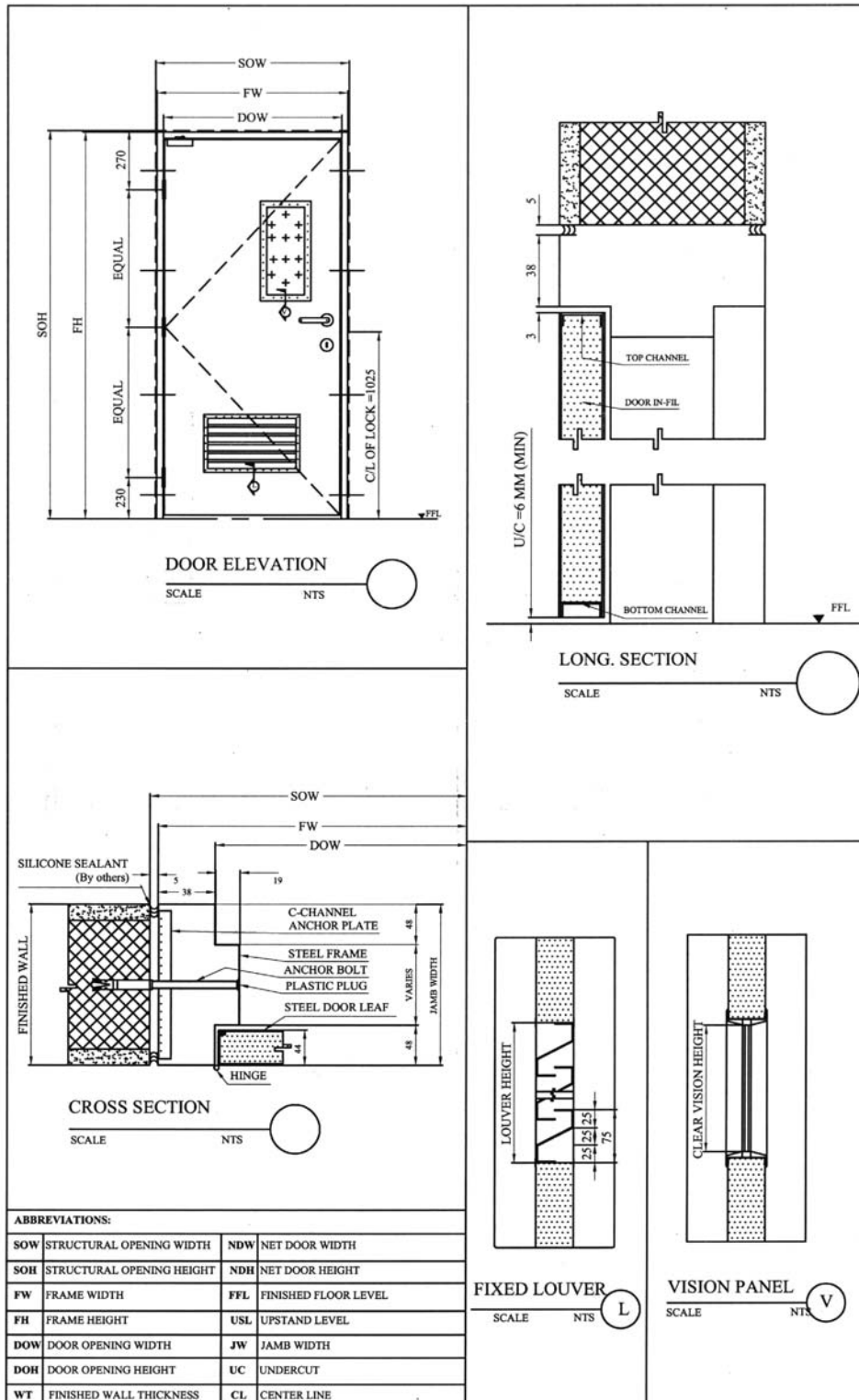



An Acknowledged Specialist

in the manufacturing of steel doors and frames



Prima
Power

Standard Finish

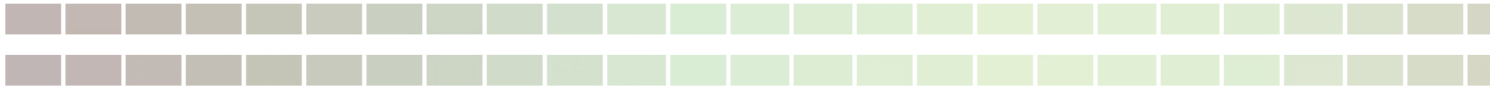

RAL 7000	RAL 7011	RAL 7030	RAL 7040	RAL 8003	RAL 9001	RAL 4001	RAL 4001	RAL 4007	RAL 5000
RAL 7001	RAL 7012	RAL 7031	RAL 7042	RAL 8004	RAL 9002	RAL 4002	RAL 4005	RAL 4008	RAL 5001
RAL 7002	RAL 7013	RAL 7032	RAL 7043	RAL 8007	RAL 9003	RAL 4003	RAL 4006	RAL 4009	RAL 5002
RAL 7003	RAL 7015	RAL 7033	RAL 7044	RAL 8008	RAL 9004	RAL 4010	RAL 5003	RAL 5009	RAL 5015
RAL 7004	RAL 7016	RAL 7034	RAL 7045	RAL 8011	RAL 9005	RAL 5017	RAL 5023	RAL 5011	RAL 5018
RAL 7005	RAL 7021	RAL 7035	RAL 7046	RAL 8012	RAL 9010	RAL 6006	RAL 6011	RAL 6002	RAL 6007
RAL 7006	RAL 7022	RAL 7036	RAL 7047	RAL 8014	RAL 9011	RAL 6003	RAL 6008	RAL 6013	RAL 6017
RAL 7008	RAL 7023	RAL 7037	RAL 8000	RAL 8015	RAL 9016	RAL 6004	RAL 6009	RAL 6014	RAL 6018
RAL 7009	RAL 7024	RAL 7038	RAL 8001	RAL 8016	RAL 9017	RAL 6005	RAL 6010	RAL 6015	RAL 6019
RAL 7010	RAL 7026	RAL 7039	RAL 8002	RAL 8017	RAL 9018	RAL 6033	RAL 6033		

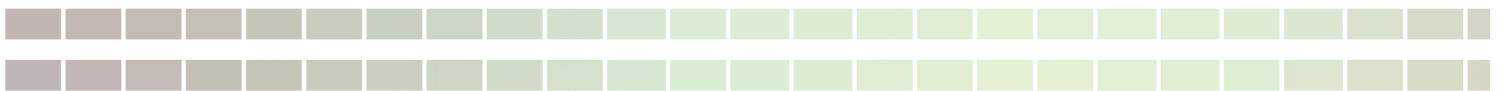

Standard Finish

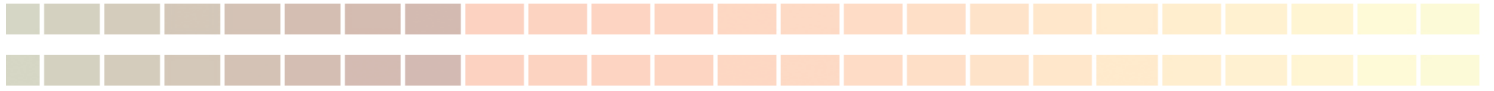

RAL 5005	RAL 5012	RAL 5019	RAL 1000	RAL 1006	RAL 1015	RAL 1020	RAL 1028	RAL 2000	RAL 2008
RAL 5007	RAL 5013	RAL 5020	RAL 1001	RAL 1007	RAL 1016	RAL 1021	RAL 1032	RAL 2001	RAL 2009
RAL 5008	RAL 5014	RAL 5021	RAL 1002	RAL 1011	RAL 1017	RAL 1023	RAL 1033	RAL 2002	RAL 2010
RAL 5022	RAL 5004	RAL 5010	RAL 1003	RAL 1012	RAL 1018	RAL 1024	RAL 1034	RAL 2003	RAL 2011
RAL 5024	RAL 6000	RAL 6001	RAL 1004	RAL 1013	RAL 1019	RAL 1027	RAL 1037	RAL 2004	RAL 2012
RAL 6012	RAL 6016	RAL 6027	RAL 1005	RAL 1014	RAL 3007	RAL 3012	RAL 3015	RAL 3018	RAL 3027
RAL 6020	RAL 6024	RAL 6028	RAL 3000	RAL 3003	RAL 3009	RAL 3013	RAL 3016	RAL 3020	RAL 3031
RAL 6021	RAL 6025	RAL 6029	RAL 3001	RAL 3004	RAL 3011	RAL 3014	RAL 3017	RAL 3022	RAL 3002
RAL 6022	RAL 6026	RAL 6032							

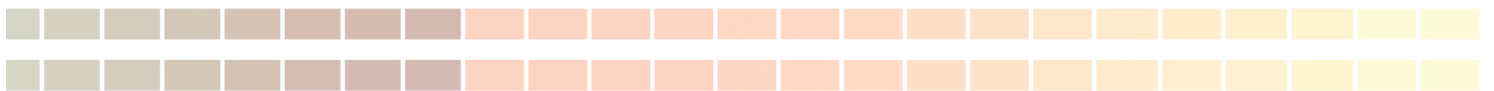

Certificates

Sulfate of Oman Ministry of Defence Engineering Services
 Certificate No.: MOD/ES-49A/2024
 Issue Date: 23/09/2024
 Expiry Date: 22/09/2027
 PRODUCT NAME/BRAND: **شهادة اعتماد منتج**
 FACTORY / COUNTRY OF ORIGIN: **شركة هندسة المصنوع**
 PRODUCT CATEGORY: **خدمات الهندسية**
 (Fire Rated and Non Fire Rated Doors) - M & T
 TRADED BY (LOCAL AGENT): Building Supplies & Services Co.L.L.C.
 Sulfate of Oman
 THIS PRODUCT HAS BEEN APPROVED TO BE USED IN MINISTRY OF DEFENCE ENGINEERING SERVICES (MOD/ES) WITH THE FOLLOWING SPECIFICATIONS AND CONDITIONS ONLY:
 Please refer to the certificate to see the technical specifications and conditions.
 This certificate is considered void if any discrepancy is found at any stage in the salient features and constituent components declared by the manufacturer or failure of supplier to provide MOD/ES with the required technical support or after sales services as agreed.

Petroleum Development Oman L.L.C.
 شركة تنمية نفط عمان
 CERTIFICATE OF REGISTRATION - PRODUCT VENDOR
 CERTIFICATE NUMBER: **REG 1002358-2022**
 VENDOR CODE: **104994**
 MANUFACTURER: PETROLEUM DEVELOPMENT
 CERTIFIES THAT: MECHANICAL & TECHNICAL
 LOCAL AGENT: Oman
 COMMERCIAL AGENCY NO.: MECHANICAL & TECHNICAL
 POSTAL ADDRESS: 1050205
 RUWI MUSCAT P.O. Box

Sulfate of Oman Ministry of Defence Engineering Services
 Certificate No.: MOD/ES-49B/2024
 Issue Date: 23/09/2024
 Expiry Date: 22/09/2027
 PRODUCT NAME/BRAND: **شهادة اعتماد منتج**
 FACTORY / COUNTRY OF ORIGIN: **شركة هندسة المصنوع**
 PRODUCT CATEGORY: **خدمات الهندسية**
 (Acoustic and Detention Doors) - M & T
 TRADED BY (LOCAL AGENT): Building Supplies & Services Co.L.L.C.
 Sulfate of Oman
 THIS PRODUCT HAS BEEN APPROVED TO BE USED IN MINISTRY OF DEFENCE ENGINEERING SERVICES (MOD/ES) WITH THE FOLLOWING SPECIFICATIONS AND CONDITIONS ONLY:
 Please refer to the certificate to see the technical specifications and conditions.
 This certificate is considered void if any discrepancy is found at any stage in the salient features and constituent components declared by the manufacturer or failure of supplier to provide MOD/ES with the required technical support or after sales services as agreed.

رقم الشهادة	الاسم	وصف المنتج	الجهة المصدرة للشهادة
CF5443	Exova (UK) Limited trading	MINERAL FIBER CORED STEEL DOORS FOR THE FOLLOWING:	Exova (UK) Limited trading
CF5136	Exova (UK) Limited trading	MINERAL FIBER CORED STEEL DOORS	Exova (UK) Limited trading
CF5135	Exova (UK) Limited trading	PAPER HONEYCOMB CORED STEEL DOORS-	Exova (UK) Limited trading
R27393	UL, UNDERWRITERS	FIRE DOOR AND WINDOW FRAMES	UL, UNDERWRITERS
R27391	UL, UNDERWRITERS	SWINGING-TYPE FIRE DOORS, SWINGING-TYPE FIRE DOORS, POSITIVE-PRESSURE TESTED	UL, UNDERWRITERS

certifire
 CERTIFICATE OF APPROVAL
 No CF 5136
 This is to certify that, in accordance with the requirements of the 1300 General Requirements for Certification of Fire Protection Products, the undermentioned product:
MECHANICAL & TECHNICAL SOLUTIONS LLC
 PO Box 1020, Ruwi - 112, Sultanate of Oman
 Tel. +968 247 14177, Fax +968 247 14177
 Have been assessed against the requirements specified below and are approved for use as indicated.
CERTIFIED PRODUCT
 Mineral fibre cored steel doors
 Signed and sealed for and on behalf of Paul Duggan Certification Manager

certifire
 CERTIFICATE OF APPROVAL
 No CF 5135
 This is to certify that, in accordance with the requirements of the 1300 General Requirements for Certification of Fire Protection Products, the undermentioned product:
MECHANICAL & TECHNICAL SOLUTIONS LLC
 PO Box 1020, Ruwi - 112, Sultanate of Oman
 Tel. +968 247 14177, Fax +968 247 110
 Have been assessed against the requirements specified below and are approved for use as indicated.
CERTIFIED PRODUCT
 Paper honeycomb cored steel doors
TECHNICAL
 TS12 Hinge Resisting Fire Doorsets v and Fram
 Signed and sealed for and on behalf of Paul Duggan Certification Manager

CERTIFICATE OF COMPLIANCE
 Certificate Number: R-R27391
 Report Reference: R27391-19911288D
 Issue Date: 2019-NOVEMBER-21
 Issued to: MECHANICAL & TECHNICAL SOLUTIONS LLC
 15, Ryan Street, Maitran
 P.O. Box 1020, P.c. 112
 Ruwi OMAN
 This certificate confirms that representative samples of SWINGING-TYPE FIRE DOORS, SWINGING-TYPE FIRE DOORS, POSITIVE-PRESSURE TESTED Swinging hollow metal fire doors for 3, 1-12 and 3/4 h locations.
 Have been investigated by UL, in accordance with the Standard(s) indicated on this Certificate.
 Additional Information:
 ANSI/UL 10C - Positive Pressure Fire Tests of Door Assemblies
 ANSI/UL 10B - Fire Tests of Door Assemblies
 See the UL Online Certification Directory at <https://ul.ulprospector.com> for additional information.
 Only those products bearing the UL Mark should be considered as being UL Certified and covered under UL's Follow-Up Services.
 Look for the UL Certification Mark on the product.
 This Certificate of Compliance does not provide authorization to apply the UL Mark. Only the UL Follow-Up Services Procedure provides authorization to apply the UL Mark.
 Paul Duggan
 Certification Manager
 Page 1 of 1

Certificates

KINGDOM OF BAHRAIN
MINISTRY OF THE INTERIOR
General Directorate of Civil Defence

PSD15/3/FP/9/2306
M/S ORBIS International Co. S.P.C.
P.O. Box: 54657
ADLIYA,
Kingdom of Bahrain

Dear Sir,

"M & T" FIRE RATED STEEL

Thank you for your submittal dated 26/07/2013. The details and information regarding the fire rated doors manufactured by Mechanical and Technical Solutions LLC (M&T) are as follows:

As the fire rated doors are to be used in the following locations:

1. T...
2. C...
3. ...

مملكة البحرين
وزارة الداخلية
الإدارة العامة للدفاع المدني

بسم الله الرحمن الرحيم

رقم الطلب : PAC15003265

التقرير الفني

المنتج :	Fire rated doors
إصناف المادة :	Fire Rated and Retardant materials
مقدم الطلب :	مكرفوت الهندسة والتجارة
الشركة المصنعة / بلد الصنع :	Mechanical and Technical Solutions LLC / OMAN
قائمة المنتجات :	

إدارة السلامة الوقائية - إشراف إمتداد الشركات

التقارير لأنظمة المباني ش.ذ.م.م

رقم الطلب	اسم الشركة	اسم المنتج	رقم الشهادة	رقم الشهادة	اسم الشركة
22-1009			CF 5126	M & T	

Intertek

Performance Test Certificate

Issued To

MECHANICAL & TECHNICAL SOLUTIONS, LLC

Intertek tested a representative sample of a standard steel door in a standard metal frame with a sound seal and then with and Zero 566A saddle, and seal plus 119WB spring bronze on the head and jamb

STANDARDS

Test Method for Laboratory Measurement of Airborne Sound Transmission Loss of Building Partitions"

Classification for Rating Sound Insulation"

RESULTS OF TEST

The system was tested and rated in accordance with the referenced standards and was determined to have a Sound Transmission Class Rating (STC) of **43 and 46**.

Reference Intertek Report Number 100413710CRT-001s, dated July 1, 2013

Intertek

Performance Test Certificate

Issued To

MECHANICAL & TECHNICAL SOLUTIONS, LLC

Intertek tested a representative sample of a standard steel door in a standard metal frame with a sound seal and then with and Zero 566A saddle, and seal plus 119WB spring bronze on the head and jamb

STANDARDS

Test Method for Laboratory Measurement of Airborne Sound Transmission Loss of Building Partitions"

Classification for Rating Sound Insulation"

RESULTS OF TEST

The system was tested and rated in accordance with the referenced standards and was determined to have a Sound Transmission Class Rating (STC) of **43 and 46**.

Reference Intertek Report Number 100413710CRT-001s, dated July 1, 2013

Intertek

Performance Test Certificate

Issued To

MECHANICAL & TECHNICAL SOLUTIONS, LLC

Intertek tested a representative sample of a standard steel door in a standard metal frame with a sound seal and then with and Zero 566A saddle, and seal plus 119WB spring bronze on the head and jamb

STANDARDS

Test Method for Laboratory Measurement of Airborne Sound Transmission Loss of Building Partitions"

Classification for Rating Sound Insulation"

RESULTS OF TEST

The system was tested and rated in accordance with the referenced standards and was determined to have a Sound Transmission Class Rating (STC) of **43 and 46**.

Reference Intertek Report Number 100413710CRT-001s, dated July 1, 2013

Certificates



Management System Certification Body No.MSCB-108

CERTIFICATE

No. 24-A-2499 Rev.0

Mechanical & Technical Solutions LLC

HO- P.O. Box 1020, P.C. 112, Ruwi, Sultanate of Oman
 Site 1-Factory (Steel Door & Powder Coating Division): Plot No. 271 & 24, Saqsouq Industrial Area, Barka, Sultanate of Oman
 Site 2-Factroy (Metal Works Division): Plot No.1002, 1003 & 312, Way No.6426, Street No.546, Ghala, Muscat, Sultanate of Oman
 Company Reg. No.: 1050205

has documented and implemented system in compliance with the requirements of

ISO 9001:2015

Quality Management Systems

for

[HO & Site 1 & Site 2]
 Manufacturing of Fire-Rated Steel Doors and Frames, Powder Coating and Wet Spray Application on Wide Range of Steel and Aluminium Products and Architectural, Structural and Metal Works

IAF Code: 17, 28

The certificate is issued on the basis of the results mentioned in the pertinent audit report. Validity of the certificate is conditionally limited by positive results of surveillance audits, which the certified company is committed to undergo. This certificate can be invalid if the certificate holder does not fulfill the conditions set out in the certification agreement.



450 North Brand Boulevard, Suite 600 - #6007 Glendale, Ca. 91203 U.S.A.

Global Inter Certification

Global Inter Certification



Management System Certification Body No.MSCB-108

CERTIFICATE

No. 24-C-1397 Rev.0

Mechanical & Technical Solutions LLC

HO- P.O. Box 1020, P.C. 112, Ruwi, Sultanate of Oman
 Site 1-Factory (Steel Door & Powder Coating Division): Plot No. 271 & 24, Saqsouq Industrial Area, Barka, Sultanate of Oman
 Site 2-Factroy (Metal Works Division): Plot No.1002, 1003 & 312, Way No.6426, Street No.546, Ghala, Muscat, Sultanate of Oman
 Company Reg. No.: 1050205

has documented and implemented system in compliance with the requirements of

ISO 14001:2015

Environmental Management Systems

for

[HO & Site 1 & Site 2]
 Fire-Rated and Non-Fire Rated Steel Doors and Frames, Powder Coating and Wet Spray Application on Wide Range of Steel and Aluminium Products and Architectural, Structural and Metal Works

The certificate is issued on the basis of the results mentioned in the pertinent audit report. Validity of the certificate is conditionally limited by positive results of surveillance audits, which the certified company is committed to undergo. This certificate holder does not fulfill the conditions set out in the certification agreement.

Initial issue date:
 Expire date:



Tyrone Dyse
 Tyrone Dyse
 Head of Certification Body

450 North Brand Boulevard, Suite 600 - #6007 Glendale, Ca. 91203 U.S.A.
<http://www.gicert.org/>

Manufacturing of Fire-Rated and Non-Fire Rated Steel Doors and Frames, Powder Coating and Wet Spray Application on Wide Range of Steel and Aluminium Products and Architectural, Structural and Metal Works



Management System Certification Body No. MSCB-108

CERTIFICATE

No. 24-O-2105 Rev.0

Mechanical & Technical Solutions LLC

HO- P.O. Box 1020, P.C. 112, Ruwi, Sultanate of Oman
 Site 1-Factory (Steel Door & Powder Coating Division): Plot No. 271 & 24, Saqsouq Industrial Area, Barka, Sultanate of Oman
 Site 2-Factroy (Metal Works Division): Plot No.1002, 1003 & 312, Way No.6426, Street No.546, Ghala, Muscat, Sultanate of Oman
 Company Reg. No.: 1050205

has documented and implemented system in compliance with the requirements of

ISO 45001:2018

Occupational Health and Safety Management Systems

for

[HO & Site 1 & Site 2]
 Manufacturing of Fire-Rated and Non-Fire Rated Steel Doors and Frames, Powder Coating and Wet Spray Application on Wide Range of Steel and Aluminium Products and Architectural, Structural and Metal Works

IAF Code: 17, 28

The certificate is issued on the basis of the results mentioned in the pertinent audit report. Validity of the certificate is conditionally limited by positive results of surveillance audits, which the certified company is committed to undergo.

This certificate can be invalid if the certificate holder does not fulfill the conditions set out in the certification agreement.



450 North Brand Boulevard, Suite 600 - #6007 Glendale, Ca. 91203 U.S.A.
<http://www.gicert.org/>

Initial issue date:
 Expire date:

Tyrone Dyse
 Tyrone Dyse
 Head of Certification Body

Brian Dawes

Brian Dawes
 General Manager
 Rules of Certification
 No. 227, Al Khuwair, Oman
gicsc.com

Plant Location Map

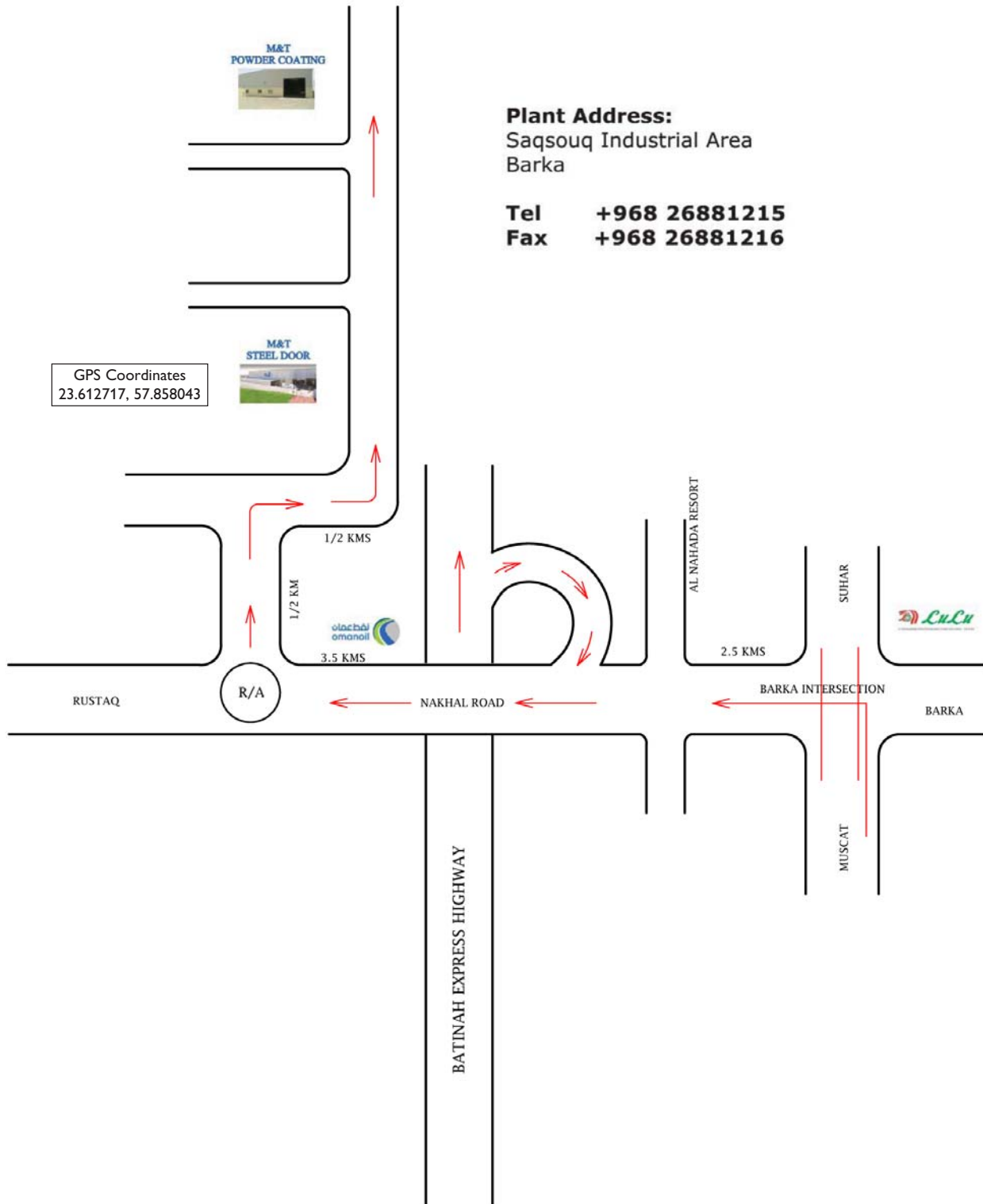



الحلول الميكانيكية و التقنية ش م م
MECHANICAL & TECHNICAL SOLUTIONS LLC
Steel Door & Powder Coating Division

Factory Address

P.O.Box 1020, Ruwi, 112, Sultanate of Oman
Tel.: 00968 26881215, Fax: 00968 26881216
E-mail: info-sd@mechanical-technical.com

Export Division

E-mail: export@mechanical-technical.com
Tel.: +968 99317867

You Tube <http://www.youtube.com/user/MandTSD>

www.mechanical-technical.com



Public Authority for
Civil Defence and Ambulance
(Sultanate of Oman)

Civil Defense
(State of Qatar)

Civil Defense
(Kingdom of Bahrain)

Civil Defense
(Dubai, UAE)

Civil Defense
(Iran)



ISO 9001 CERTIFIED
ISO 14001 CERTIFIED
ISO 45001 CERTIFIED

M&T-SLS-FM-07
Rev. 3